

Confidential

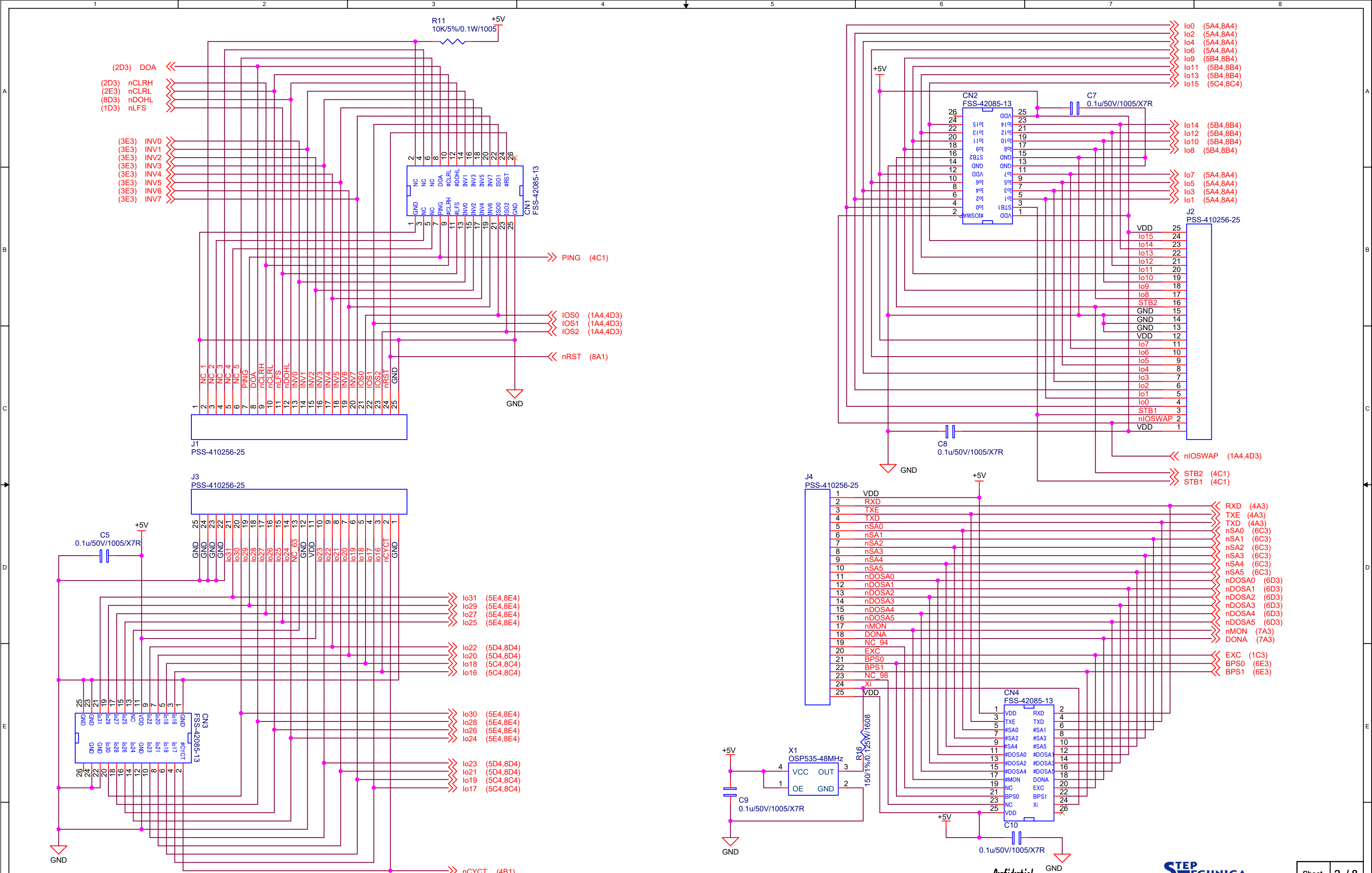

Design	M.Adachi	DRAW No.	P10431-100		
Checked	H.Miyamoto	DRAW Name	IB-46 Circuit Diagram		
Approved	T.Maeda	Date	Thursday, May 25, 2023		
Sym	Revision	ECO.No.	Date	Revised	Approved



Confidential



Design	M.Adachi	DRAW No.	<DRAW NO.>
Checked	H.Miyamoto	DRAW Name	IB-46 Circuit Diagram : DB I/F-1
Approved	T.Maeda	Date	Thursday, May 25, 2023
Sym	Revision	ECO.No.	Date
			Revised
			Approved

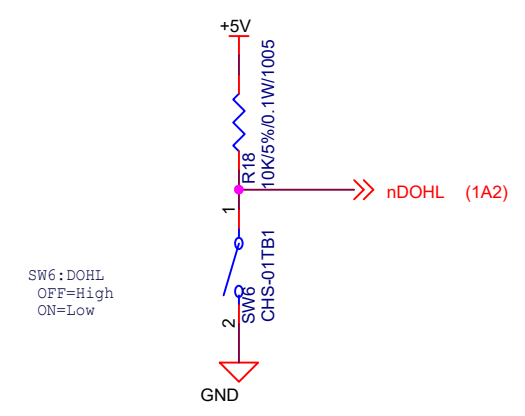
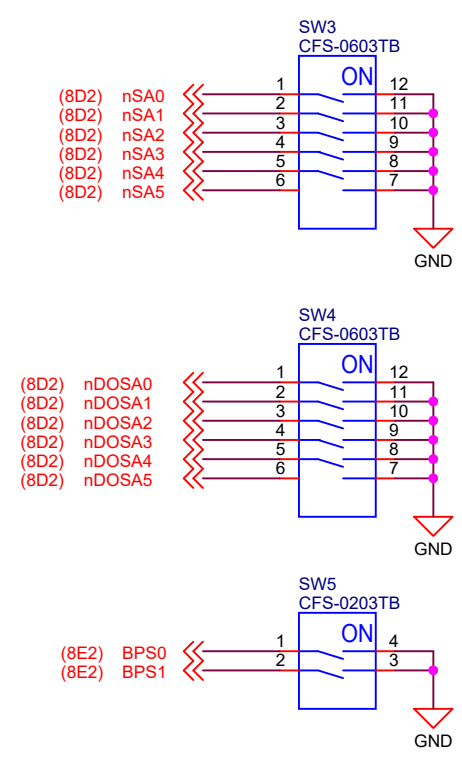
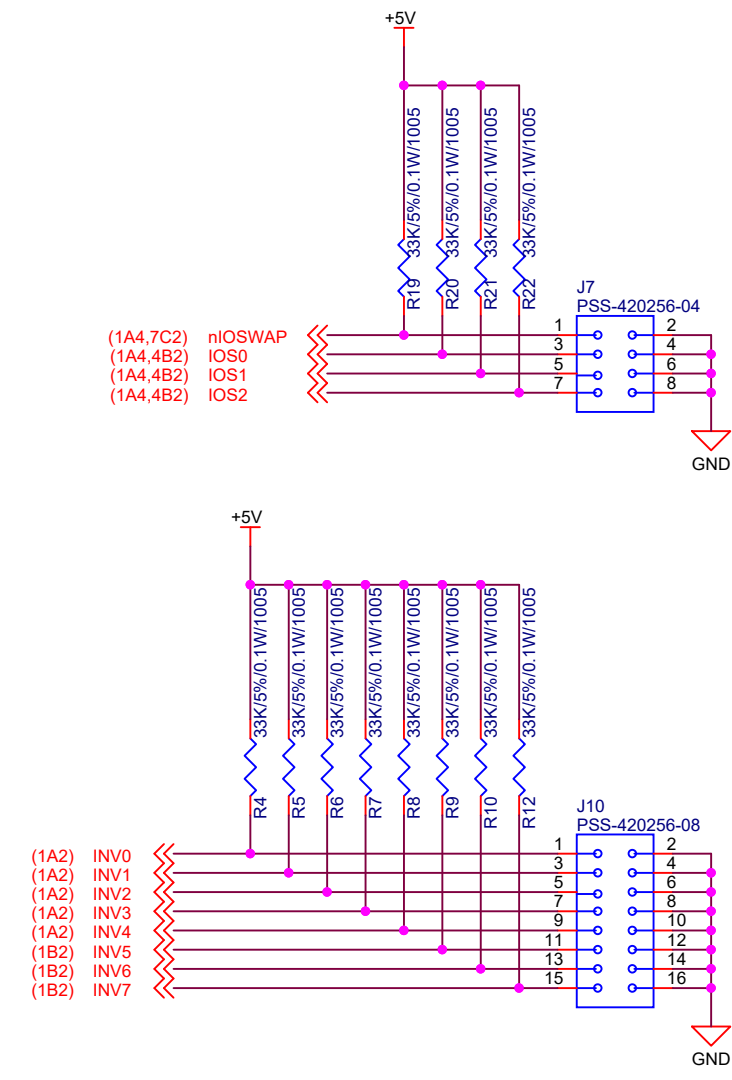
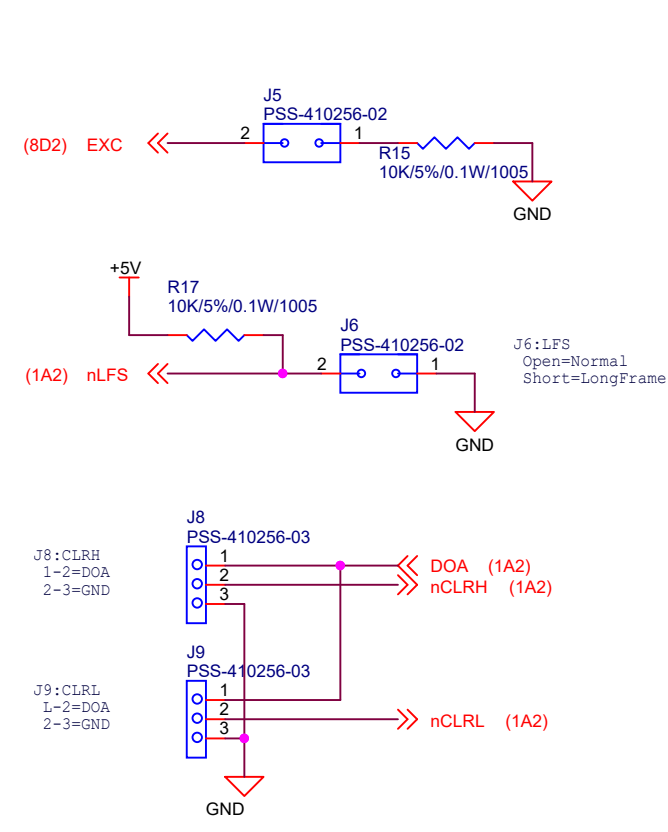
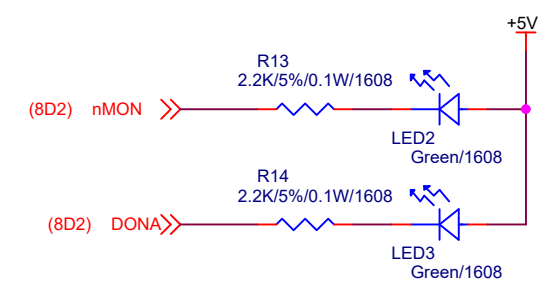
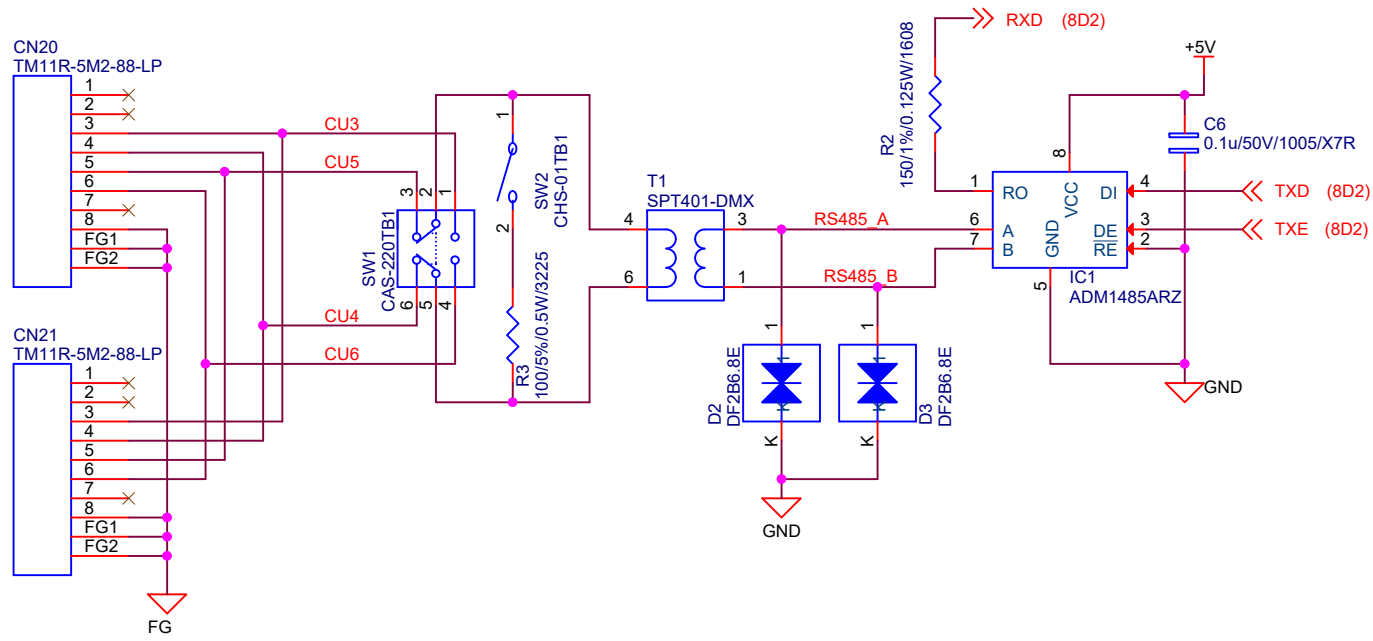

Confidential



Design	M.Adachi	DRAW No.	P10431-100	
Checked	H.Miyamoto	DRAW Name	IB-46 Circuit Diagram : DB I/F-2	
Approved	T.Maeda	Date	Thursday, May 25, 2023	A3
Sym	Revision	ECO.No.	Date	Revised
				Approved

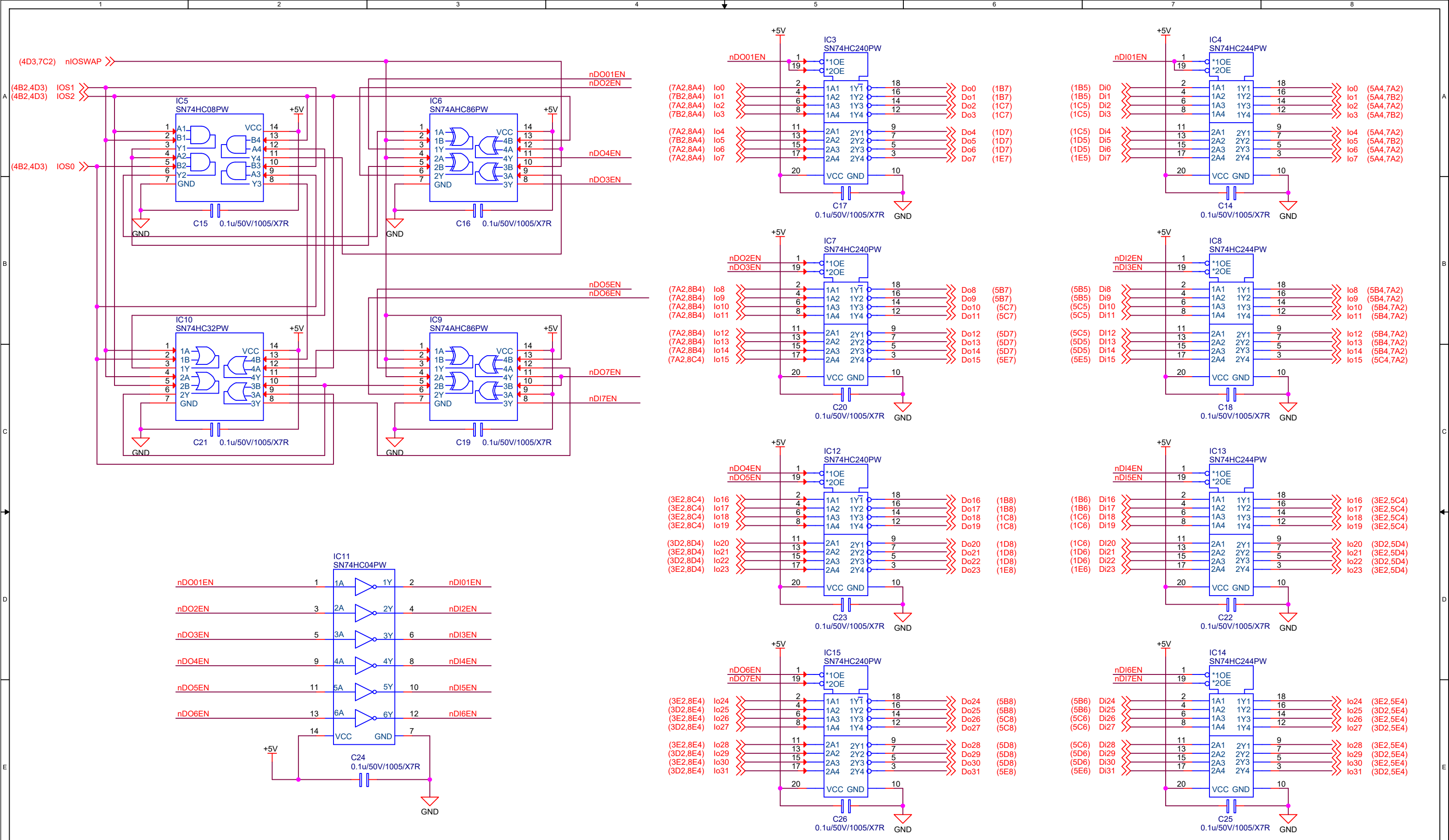

Confidential



Design	M.Adachi	DRAW No.	P10431-100		
Checked	H.Miyamoto	DRAW Name	IB-46 Circuit Diagram : I/O Selector		
Approved	T.Maeda	Date	Thursday, May 25, 2023	A3	
Sym	Revision	ECO.No.	Date	Revised	Approved

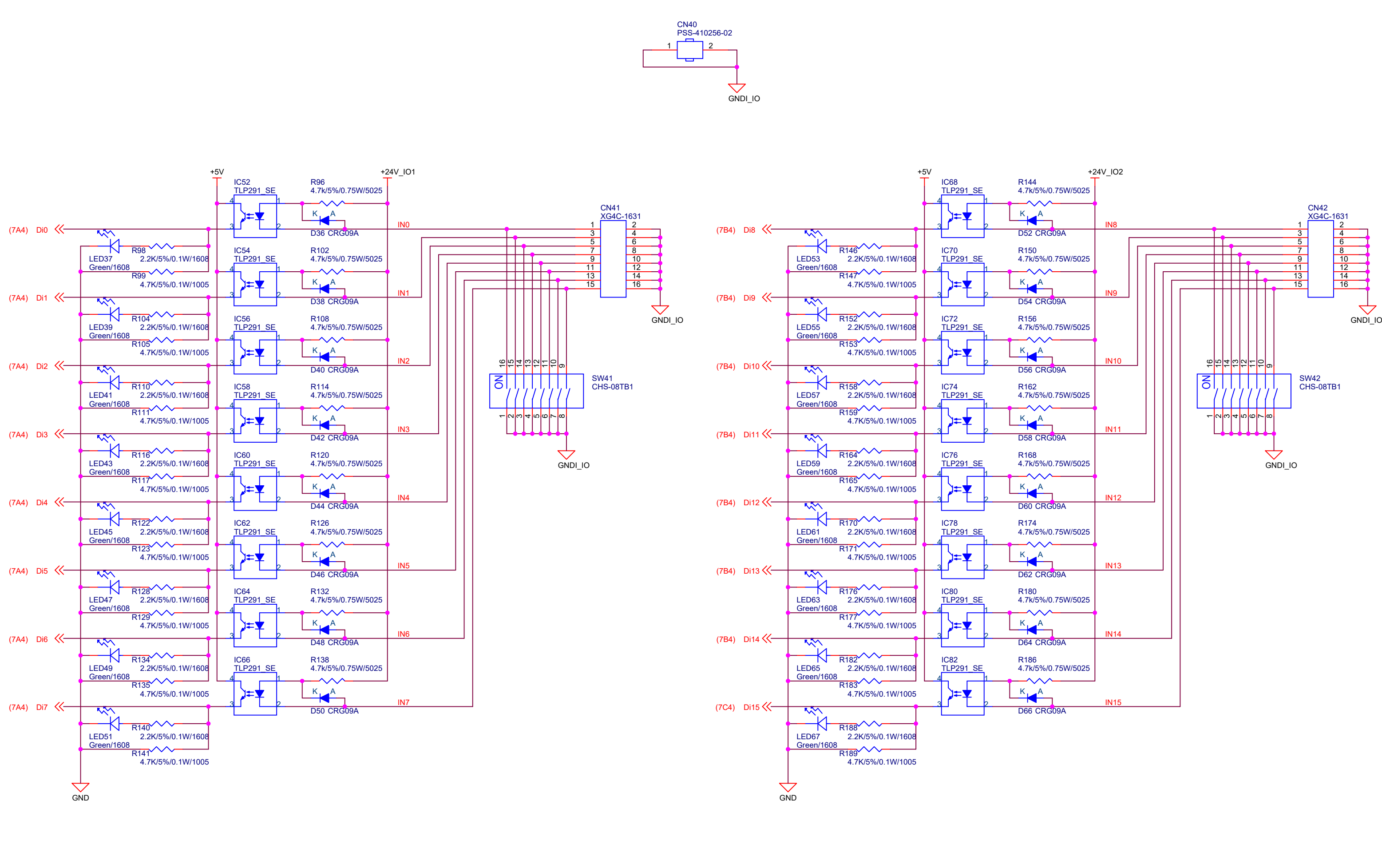

Confidential



Design	M.Adachi	DRAW No.	P10431-100		
Checked	H.Miyamoto	DRAW Name	IB-46 Circuit Diagram : Input-1		
Approved	T.Maeda	Date	Thursday, May 25, 2023		A3
Sym	Revision	ECO.No.	Date	Revised	Approved

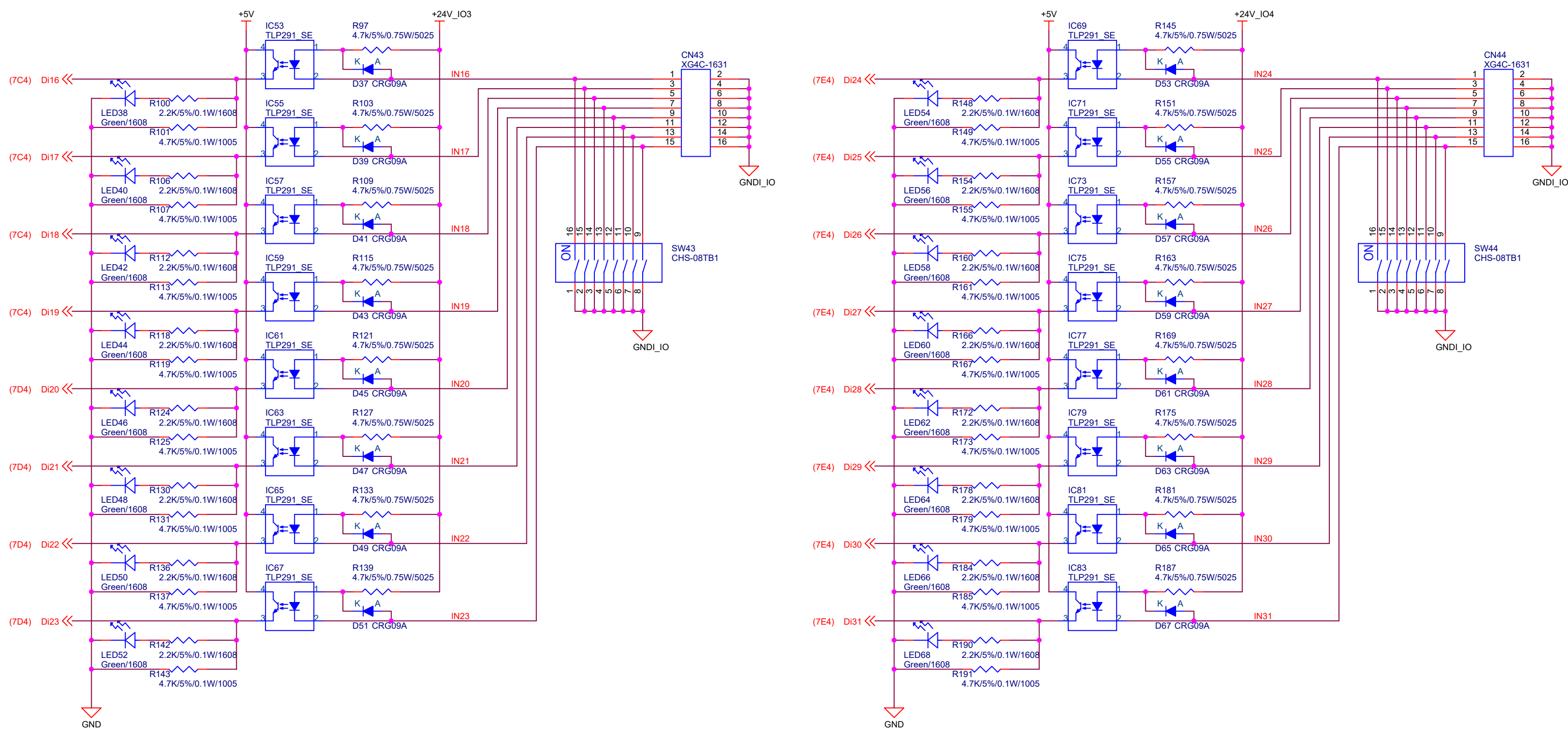

Confidential



Design	M.Adachi	DRAW No.	P10431-100		
Checked	H.Miyamoto	DRAW Name	IB-46 Circuit Diagram : Input-2		
Approved	T.Maeda	Date	Thursday, May 25, 2023	A3	
Sym	Revision	ECO.No.	Date	Revised	Approved

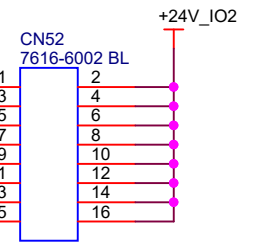
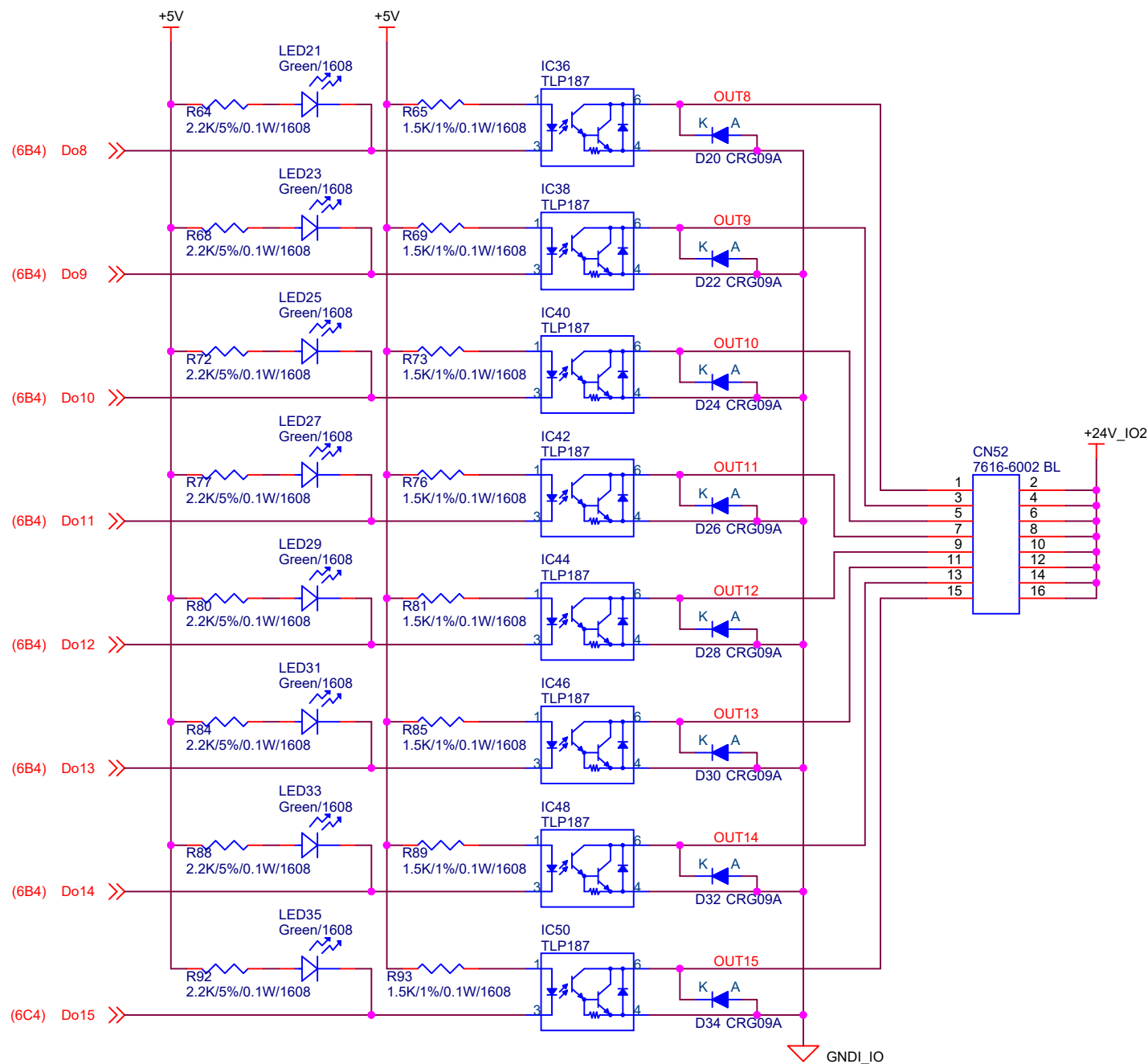
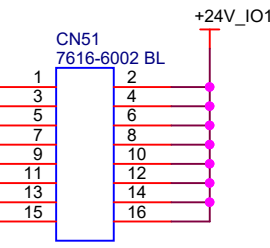
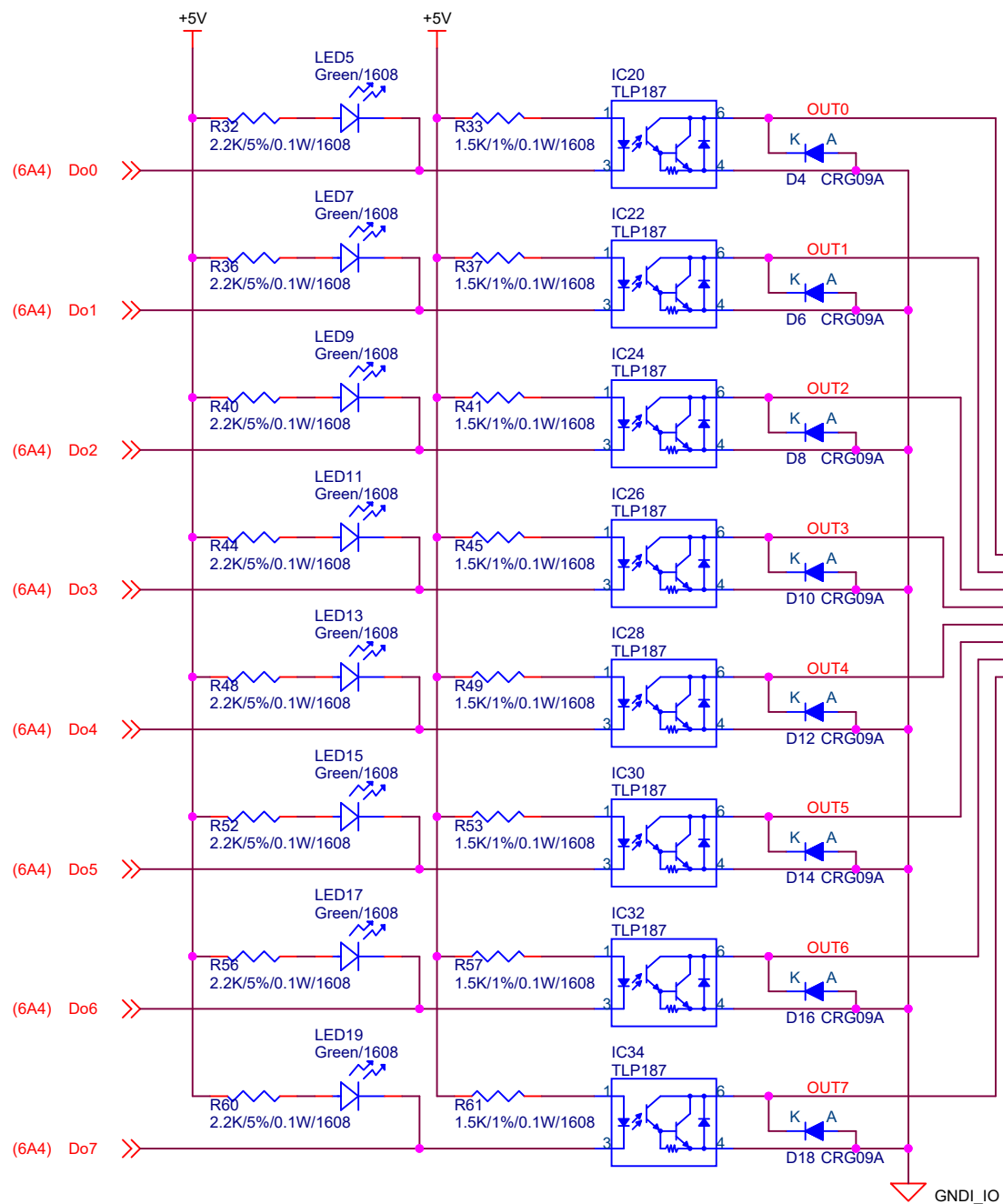
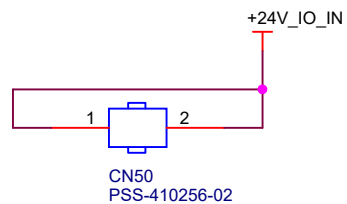

Confidential



Design	M.Adachi	DRAW No.	P10431-100		
Checked	H.Miyamoto	DRAW Name	IB-46 Circuit Diagram : Output-1		
Approved	T.Maeda	Date	Thursday, May 25, 2023		A3
Sym	Revision	ECO.No.	Date	Revised	Approved



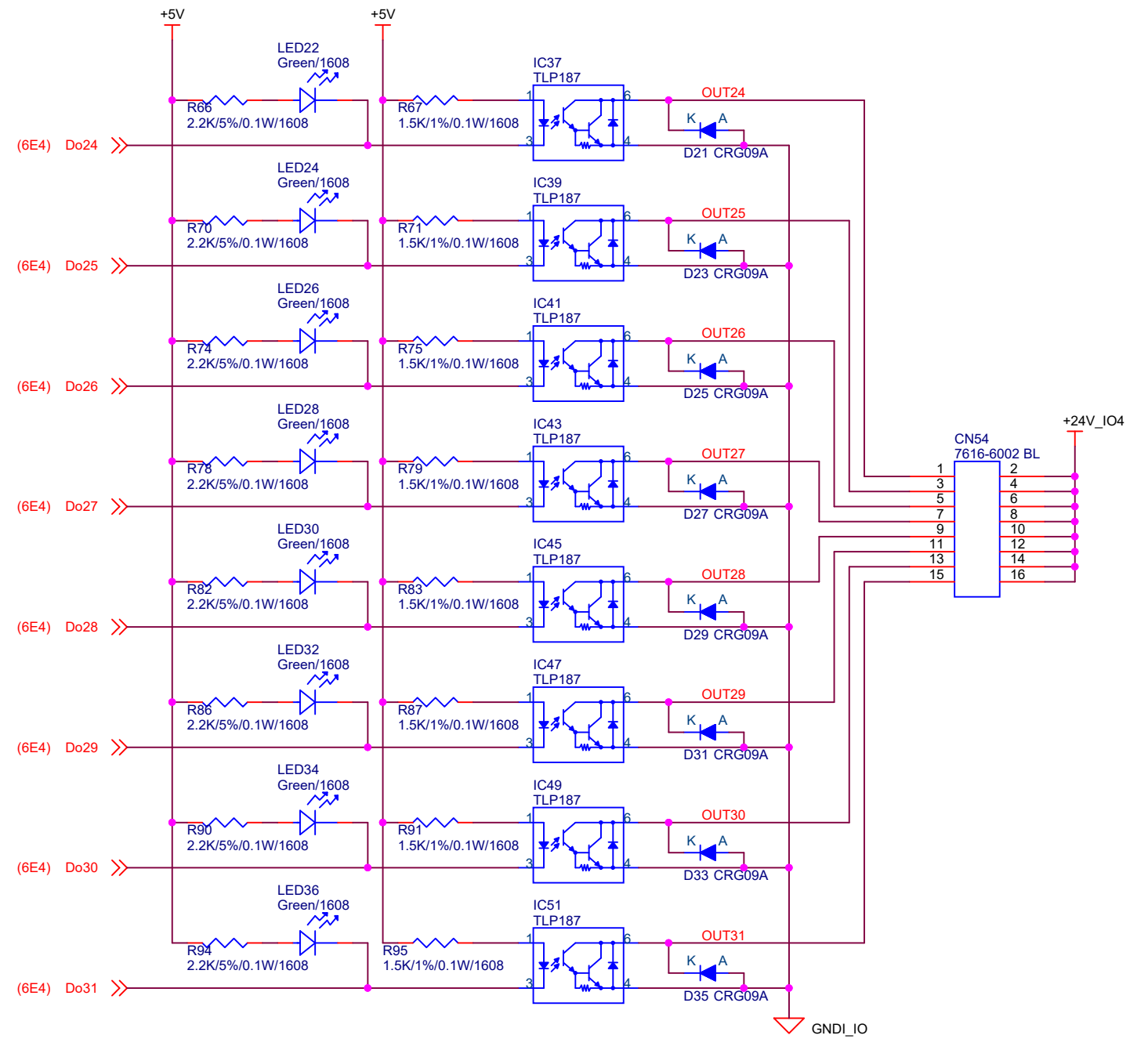
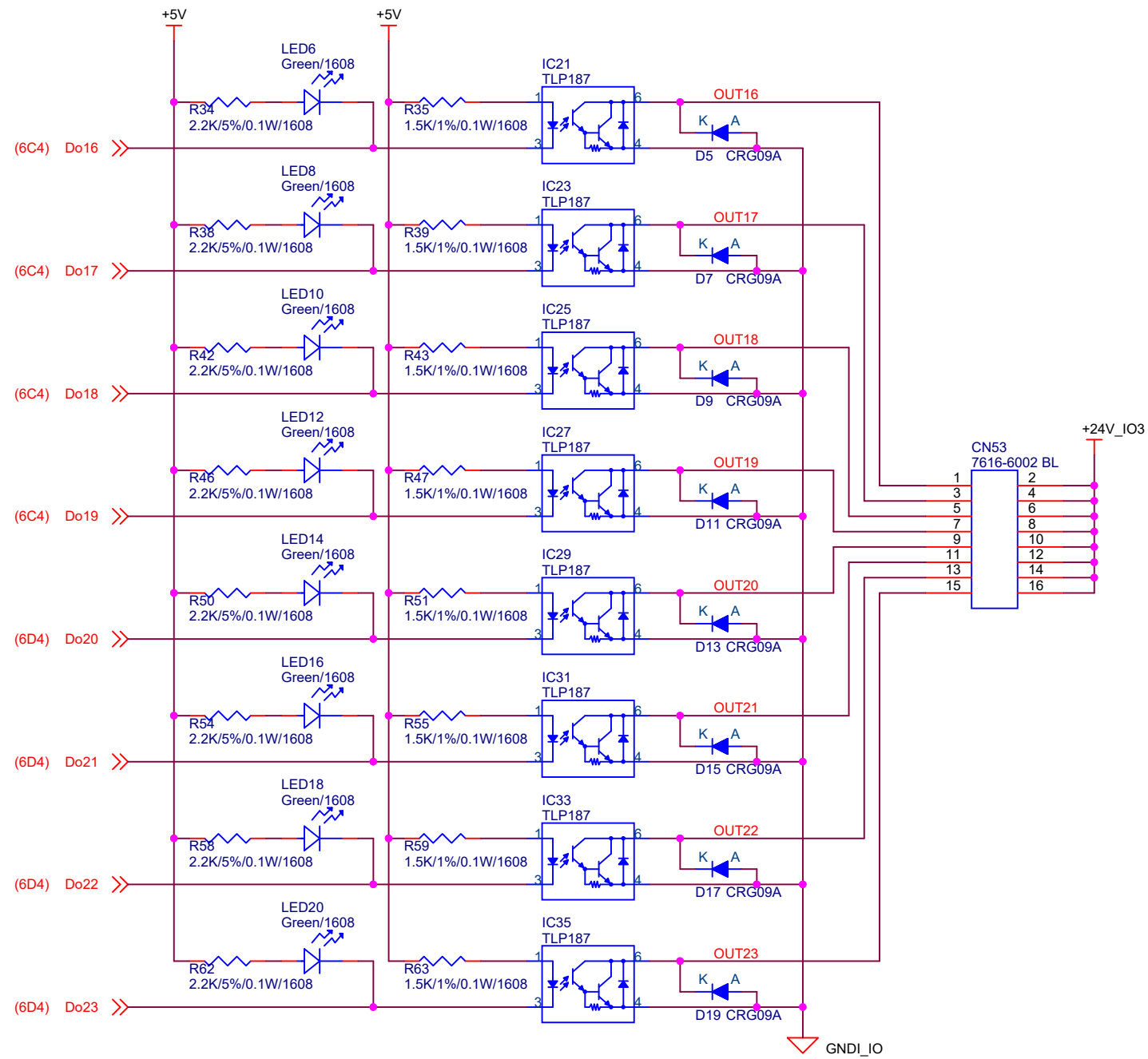

Confidential



Design	M.Adachi	DRAW No.	P10431-100	
Checked	H.Miyamoto	DRAW Name	IB-46 Circuit Diagram : Output-2	
Approved	T.Maeda	Date	Thursday, May 25, 2023	A3
Sym	Revision	ECO.No.	Date	Revised